

B.S.A V.TWINS k.START SPRING P.NO: M162

GEARBOX AND CONTROL PARTS.

CORNUCOPIA 
ENTERPRISES

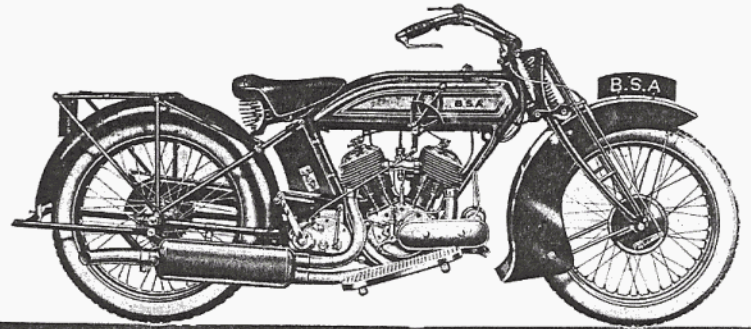
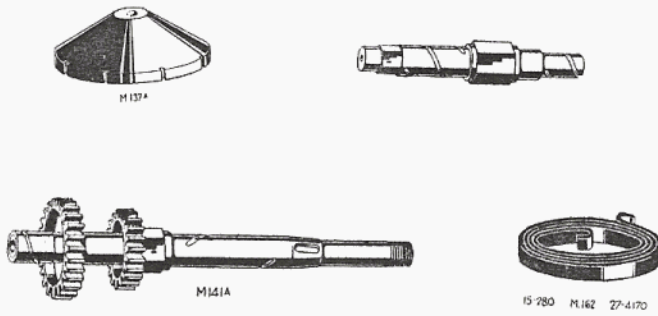

B.S.A 986 hp. model G28 Colonial

Fits the following models

- 1924 4. ¼ HP (6 H.P. and 8 H.P. V.TWINS)
- 1925 / 6 5.57 H.P. (7.70 H.P. 9.86 H.P. V. TWINS)
- 1927 7.70 H.P. De Lux. 9.86 H.P. De Lux + Colonial
- 1928/9 7.70 H.P. 9.86 H.P. De Lux. 9.86 World Tour.
- 1930 G-30-16. (1931 G31-12) (1932 W.Tour G32-10)
- 1933 G33-16. EURO 12.24 + Vat + MWS:

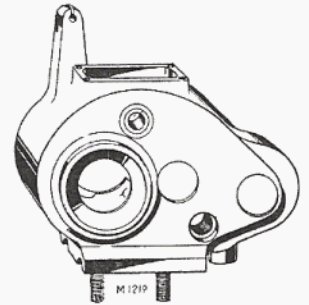

LARGE STOCKS OF V.TWIN, G.BOX, CLUTCH SPARES (USED)
1926 - 40 G.BOX CASES, SHAFTS, GEARS, ETC.

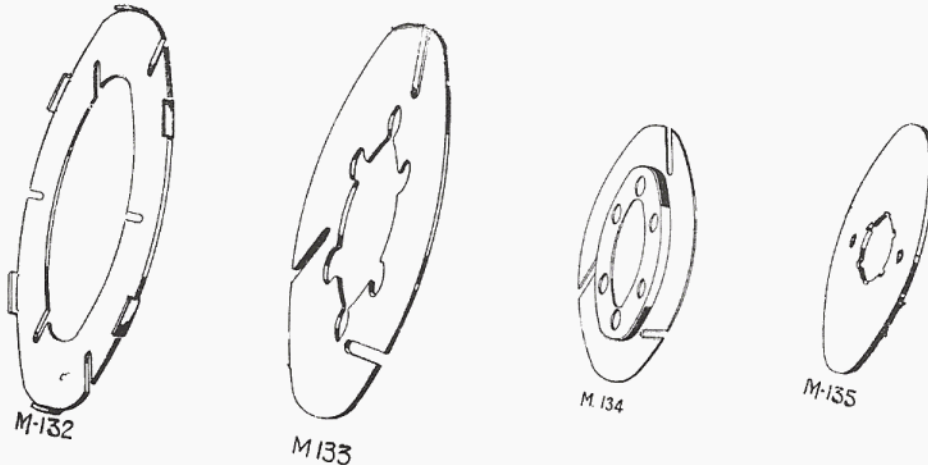
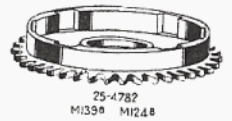

REPLICA B.S.A CLUTCH PLATES (STEEL) FOR SLOPER MODELS, V. TWINS. (B.S.A PART NOS) M.132, M.133, M.134, M,135.

M, 135 Clutch Spring thrust Plate EURO 6.20 (one needed)

M, 132 Clutch Driving Plate EURO 15.50 (each) (3 Needed)

M, 133 Clutch Driven Plate EURO 7.00 (each) (2 Needed)

M ,134 Clutch Driven PLATE EURO 30.00 (recessed) (one needed)

FITS Most Singles 500, 770, 1,000cc V.Twins 1924 To 1940

ALL PRICES +19% V.A.T ALLE PREISE+19% M.W.S

B.S.A V.TWINS GEARBOX MAINSHAFT AND LAYSHAFT BEARINGS. K:191 MAINSHAFT K:193 LAYSHAFT

Fits The Following Models Years.

- 1924 K191 All Models Except 2 ¼ H.P.
K193 Fits 4 ¼ H.P. 6 HP 8 HP.
- 1925 K191 All Models Except 2.49 H.P.
K193 Fits 5.57 H.P. 7.70 H.P. 9.86 H.P.
- 1926 K193 Fits 5.57 H.P. 7.70 H.P. 9.86 H.P.
K191 All Models Except 2.49 HP
- 1927/8 K191 (77.4027) Fits All Models Except 2.49 H.P.
K193 7.70 H.P. DE LUX 9.86 H.P. DE LUX 9.86 COLONIAL
- 1929 K191 All Models Except 2.49 H.P.
K193 7.70 H.P. Light + DE LUX 9.86 DE LUX + WORLD TOUR
- 1930 K191 All Models Except B 30-3-4 L.30-5-6
K193 Fits 9.86 W.Tour G.30-16
- 1931 K191 All Models Except B.31-1-2-3 And L31-4
K193 9.86 H.P. W.Tour G31-12
- 1932 K191 All Models Except B21-1 + Export + L32-2-3
K193 9.86 S.V. W.Tour G32-10
- 1933 K191 4.99 S.V. W33-6 M33-10 9.86 S.V. W.Tour G33-13
K193 9.86 S.V. W.Tour G33-13
- 1934 K191 Fits 9.86 S.V. G.34-14
K193 Fits 9.86 S.V. G.34-14
- 1935 K191 fits 9.86 S.V. G35-14
K193 Fits 9.86 S.V. G35-14

K191 EURO 46.50

K193 EURO 22.47

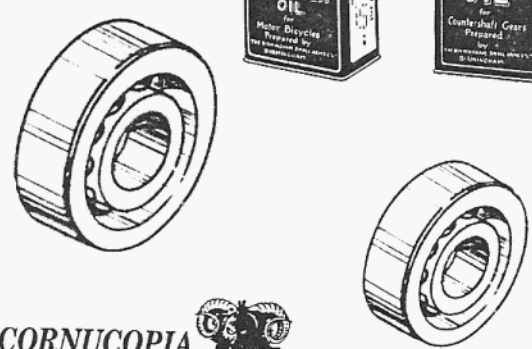

CORNUCOPIA ENTERPRISES

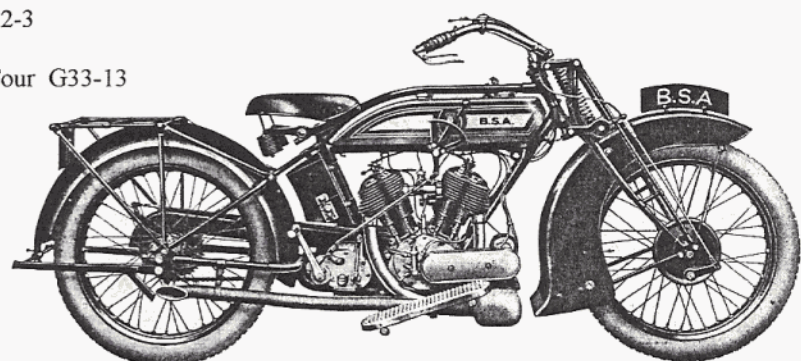

BSA 9.86hp model G28 de luxe

M 248 CHAINCASE INSPECTION PLATE

(To FIT CAST ALLOY CHAINCASE)

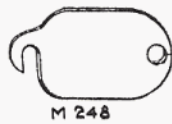

- 1924 Fits Models 4 ¼. H.P. 6. H.P. 8. H.P.
- 1925/6 Fits 5.57 H.P. 7.70 H.P. + 9.86 H.P. V. Twins
- 1927/8 Fits 7.70 H.P. 9.86 H.P. + 9.86 H.P. V. Twins
- 1929 Fits 7.70 H.P. Light + 9.86 H.P. D.Lux+W.Tour, (V.Twins)
- 1932 Fits G32-10 9.86 S.V. W.Tour
- Two Needed Per Machine Euro 7.00 Each

B. S. A.

CYLINDER VALVE SPRING COVER KNOB (24.397) STAINLESS



27-372
24-397

- 1930+31+32 Fits All V.Twins
- 1933 Fits Models 5.95 S.V. D.Lux M33-10 G33-13 V.Twins
- 1934 Fits Models 5.95 S.V. M34-12 + V. Twins G34-14
- 1935 Fits Models 5.95 S.V. M35-10 + G35-14 V.Twins
- 1936 Fits 9.96 S.V. V.Twins
- 1937/8/9 40 G14 V.Twins

24.397 EURO 14.00 EACH

CYLINDER VALVE SPRING COVER STUD (25.51) STAINLESS



25-51

- 1930/1 Fits All V.Twins
- 1932/33 Fits G.32-10 9.86 S.V.
- 1934/5 Fits G35-14 All V.twins
- 1936/7/8/9-40 G14 V.twins

25.51 EURO 11.00 EACH

CORNUCOPIA ENTERPRISES

CHAINCASE (cast aluminium type)

Various used sections in stock (Genuine BSA)
EURO 100.00 to 130.00 Per Section

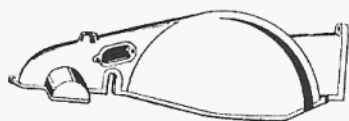

26-8787



26-8789

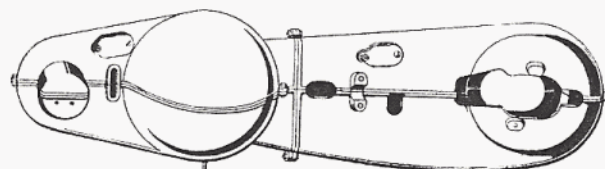

26-8786



26-8788

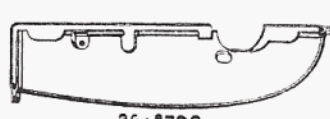

26-8790

Please note all drawings covered by Database Copywrite
ALWAYS WANTED BRITISH MOTORCYCLE SPARES W.H.Y. Drawings by N.R. Bridwell, Germany ©

ALL PRICES +POSTAGE + 19% VAT. ALLE PREISE + VERSAND GELTEN ZZGL M.W.S. (19%)